

ADMIRALTY SIGNAL ESTABLISHMENT

Specification AD/CV12/Issue 3. Dated 13.11.46. To be read in conjunction with K1001, ignoring clauses:- 5.2, 5.3 and 5.8.	<u>SECURITY</u>	
	<u>Specn.</u> Restricted	<u>Valve</u> Unclassified

<u>TYPE OF VALVE</u> :- Mercury Vapour, Grid Controlled, Gas Discharge Triode.	<u>MARKING</u> See K1001/4. <u>Additional Marking</u> Serial No.
<u>CATHODE</u> :- Directly Heated.	
<u>ENVELOPE</u> :- Glass, unmetallised.	
<u>PROTOTYPE</u> :- E1191. (High Rating).	

<u>RATING</u>	Note	<u>BASE AND DIMENSIONS</u> See Fig. 1.
Filament Voltage D.C. or A.C. (V) 2.5		<u>TOP CAP</u> See Fig. 2.
Filament Current (A) 43		<u>PACKING</u> See K1001/7. <i>PACKAGING</i> <i>SEE K1001/7</i>
Max. Peak Anode Voltage (kV) 15	B	
Max. Peak Anode Current (A) 200	B	
Operating Mercury Con- densation Temperature Range (°C) 60-70	B	

NOTES

- A. The symbol V_g represents the striker voltage throughout.
- B. These ratings are for operation with:-
- (i) Repetition frequency of 500 p.p.s.
 - (ii) Pulse length of 2 μ secs.
 - (iii) Pulse sensibly square in shape.
 - (iv) Load resistance 37.5 ohms.
 - (v) Approx. rate of rise of pulse from 10% max. value to 90% max. value:- 600 A/ μ sec. min. rate of rise during testing 400 A/ μ sec.
- C. The optimum mercury condensation temperature is to be maintained by means of warmed air from a special fitting containing a thermostat fitted in an approved manner. (See Appendix.)
- D. The Tufnol Tube (Fig. 1.) shall be firmly fixed to the base by an approved method.

TESTS

To be performed in an approved circuit in addition to those applicable in K1001.

	Test Conditions			Test	Limits		No. Tested
	Vf (V)	Va (kV)	Vg (V)		Min.	Max.	
a	2.5	-	-	If (A)	35	45	100%
b	2.5	-	-100	Grid cathode leakage current (mA)	-	1.0	100%
c	2.5	15	-50	Operation			100%
	Operation, with conditions as in Note B, for 15 mins.			The valve shall operate satisfactorily after a running up period no more lengthy than that described in the Appendix. The pulse breadth from valve and network shall be normal. The valve shall not deteriorate.			
d	As in test (c).			Ia (A)	200	-	100%

APPENDIX.Procedure to be carried out during operation of CV12.

1. NEW VALVES. (a) The filaments only should be run for at least 30 mins., before any H.T. is applied, to ensure that all mercury is driven off the filaments and that the valve is at operating temperature.
 - (b) Apply H.T. in the following stages, taking one minute for each stage:-
 - 0 to 5 kV.
 - 5 kV to 7.5 kV.
 - 7.5 kV to 10 kV.
 - (c) During the next stage, 10 to 15 kV, increase the H.T. slowly, watching for signs of erratic and early firing, and for indications of arcing. Should these faults occur, reduce the H.T. to a point where the valve is stable, wait 10 minutes and try again.
2. USED VALVES. (a) After a shut-down period of more than 30 mins. the procedure under 1 above should be used.
 - (b) After a shut-down period of less than 30 mins:- For 5 mins. or less : as in 1 (b) above, after running filaments only for 3 mins. For 5 to 30 mins: run the filament only for a period of at least 5 mins. less than the shut-down period and then proceed as in 1 (b) above.

FIG. 1.
OUTLINE DIMENSIONS
& CONNECTIONS

HOLE $\frac{3}{8}$ " DIA. TO TAKE HEATER UNIT.

VIEW AT AA.

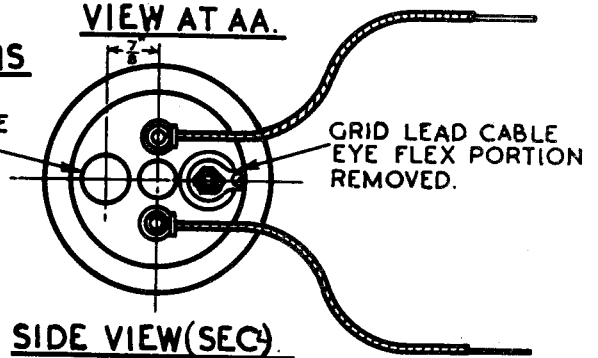

FRONT VIEW.

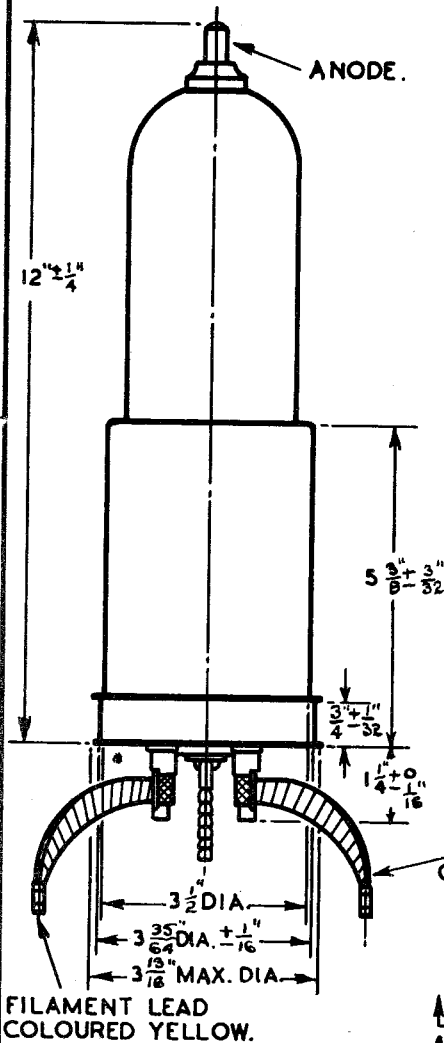

SIDE VIEW (SEC.)

$2\frac{5}{8}$ (MAX DIA.)

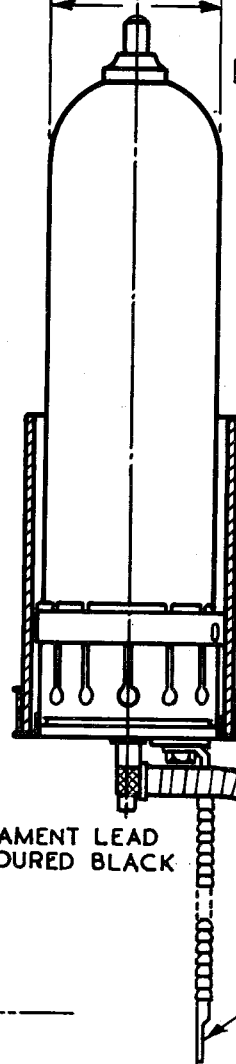
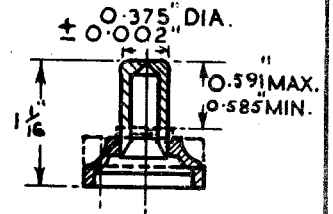
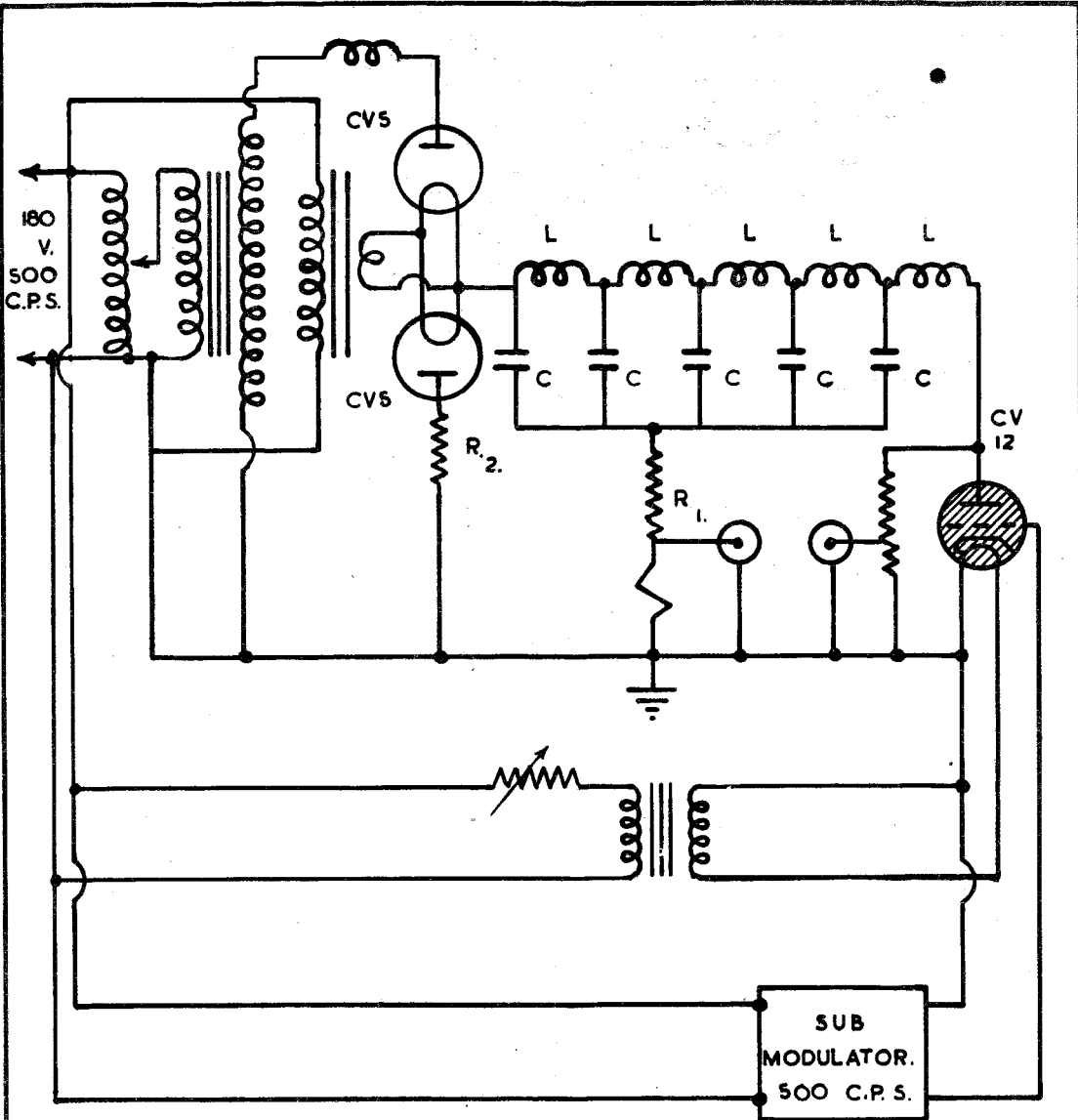

FIG. 2.
DETAILS OF TOP CAP.





L = 8 μ H.

C = 0.005 μ F.

R₁ = 37.5 OHMS. APPROX.
(6 240 VOLT. 250 WATT.
LAMPS IN PARALLEL)

R₂ = 250 OHMS.

NOTE:- THIS TEST CIRCUIT IS RECOMMENDED FOR USE IN TEST (C) AND TEST (D).